



**BMW E53 X5 Rear Differential Locker
Installation Instructions - [Click HERE to Shop](#)**



**Skill Level
2 - Moderate**
Some Experience
Recommended



Proper service and repair procedures are vital to the safe, reliable operation of all motor vehicles as well as the personal safety of those performing the repairs. Standard safety procedures and precautions (including use of safety goggles and proper tools and equipment) should be followed at all times to eliminate the possibility of personal injury or improper service which could damage the vehicle or compromise its safety.

INSTALLATION NOTES

- **RH** refers to the *passenger side* of the vehicle.
- **LH** refers to the *driver side* of the vehicle.
- Always use the proper torque specifications.
- If applicable to this installation, torque specifications will be listed throughout the document and at the end as well.
- Please read all of these instructions and familiarize yourself with the complete process **BEFORE** you begin.

GENERAL PREPARATION AND SAFETY INFORMATION

ECS Tuning cares about your health and safety, please read the following safety information. This information pertains to automotive service in general, and while it may not pertain to every job you do, please remember and share these important safety tips.

- Park your car in a safe, well lit, level area.
- Shut the engine off and remove the key from the ignition switch.
- Make sure any remote start devices are properly disabled.
- **ALWAYS** wear safety glasses.
- Make sure the parking brake is applied until the vehicle is safely lifted and supported.
- Whether lifting a vehicle using an automotive lift or a hydraulic jack, be sure and utilize the factory specified lift points.
- Lifting a vehicle in an incorrect location can cause damage to the suspension/running gear.
- **ALWAYS** support the vehicle with jack stands.
- **ALWAYS** read and follow all safety information and warnings for the equipment you are using.



NEVER get underneath a vehicle that is supported only by a jack, and **ALWAYS** make sure that the vehicle is securely supported on jack stands.

INSTALLING THE DIFFERENTIAL LOCKER

Step 1: 14mm Hex (Allen), 18mm, 21mm Socket & Ratchet

Remove the drain plug (arrow) and drain the differential fluid, then remove the differential by doing the following:

- Disconnect the axles from the differential.
- Disconnect the driveshaft from the differential.
- Support the differential from below.
- Remove the bolts (circled in **RED**) and remove the differential.

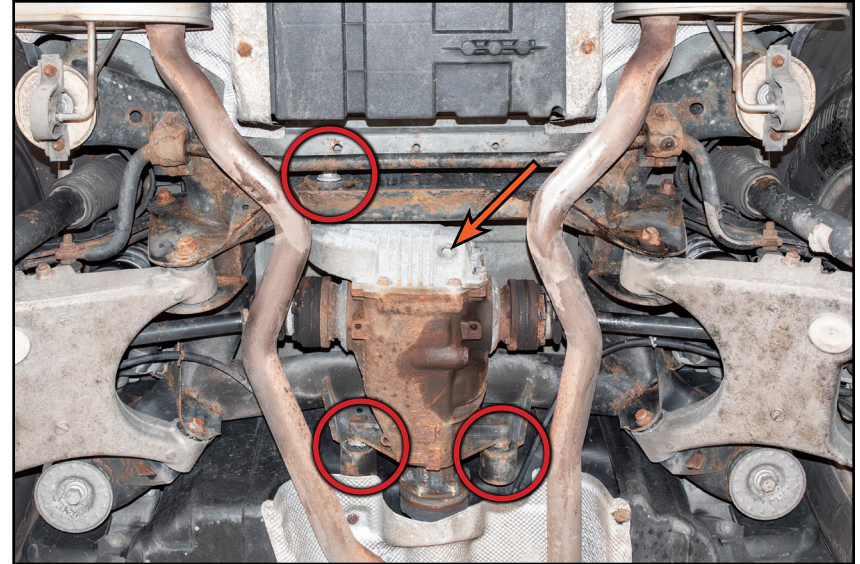

Step 2: 16mm Socket & Ratchet

Remove the eight bolts (circled in **RED**) and pry the differential cover off of the case.



INSTALLING THE DIFFERENTIAL LOCKER

Step 3:

Clean any leftover gasket material from both mounting faces, then thoroughly clean and dry the inside of the differential case.

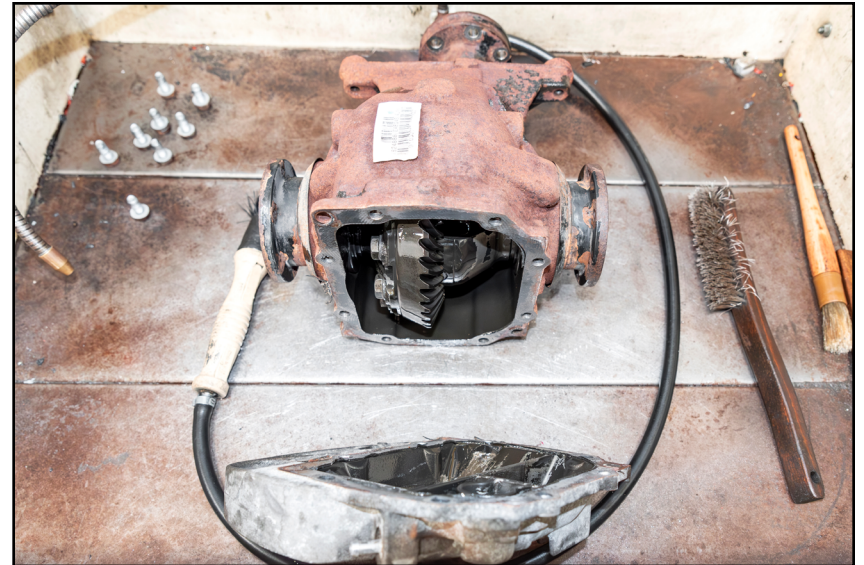

Step 4: Hammer, Punch

Carefully drive each output shaft out of the differential as shown.

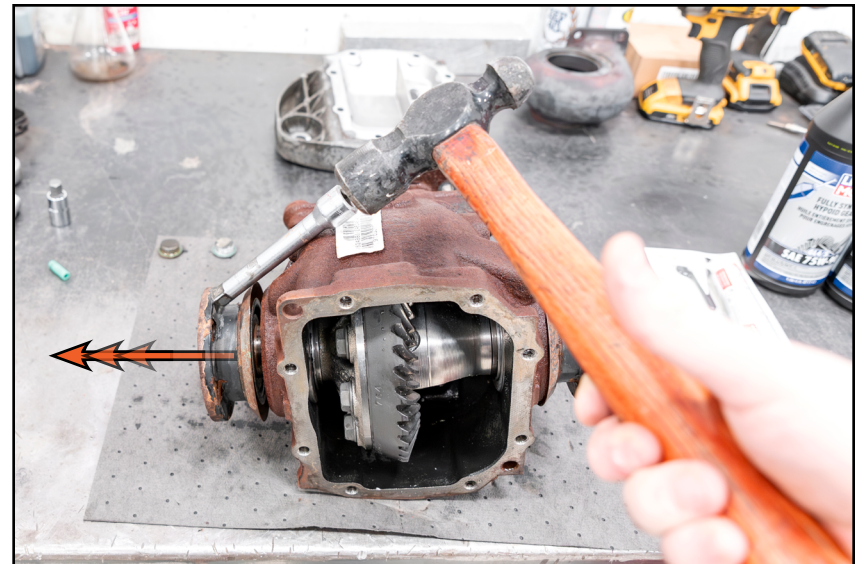

INSTALLING THE DIFFERENTIAL LOCKER

Step 5: Pry Bar

Pry the output shaft seal (highlighted in **GREEN**) out of each side of the differential case.

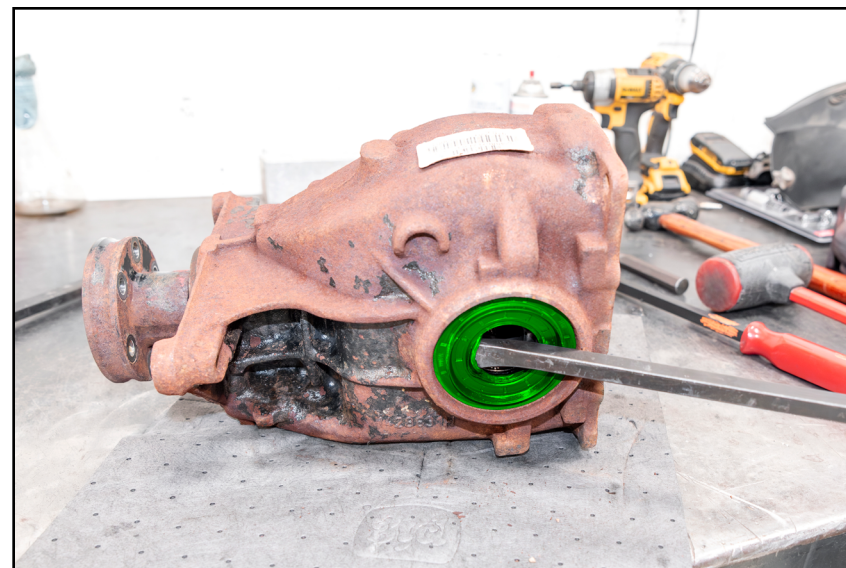

Step 6: Snap Ring Pliers

Carefully compress and remove the snap ring from each side of the differential case.



Snap ring sizes vary and are side-specific, be sure to label which side of the differential each snap ring came out of.

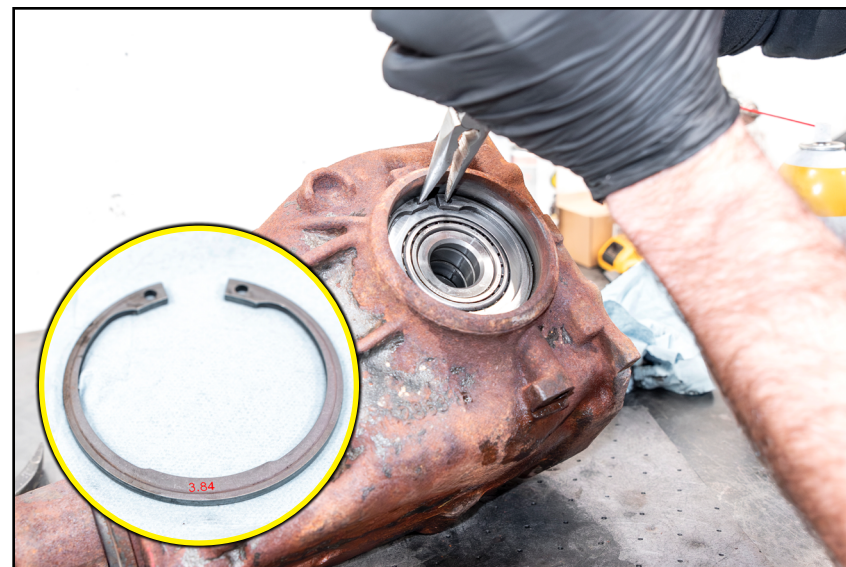

INSTALLING THE DIFFERENTIAL LOCKER

Step 7:

Carefully slide each differential bearing race (highlighted in **GREEN**) out of the case.



Depending on the condition of your differential, you may need to remove some corrosion build-up from the bore to allow the bearing race to slide out easily.



Step 8:

Thoroughly clean and inspect the shafts, snap rings, and bearing races and lay them out in the positions they were removed as shown.



INSTALLING THE DIFFERENTIAL LOCKER

Step 9:

Slide the differential assembly towards the RH side of the case as far as it will go, then pivot it out as shown.

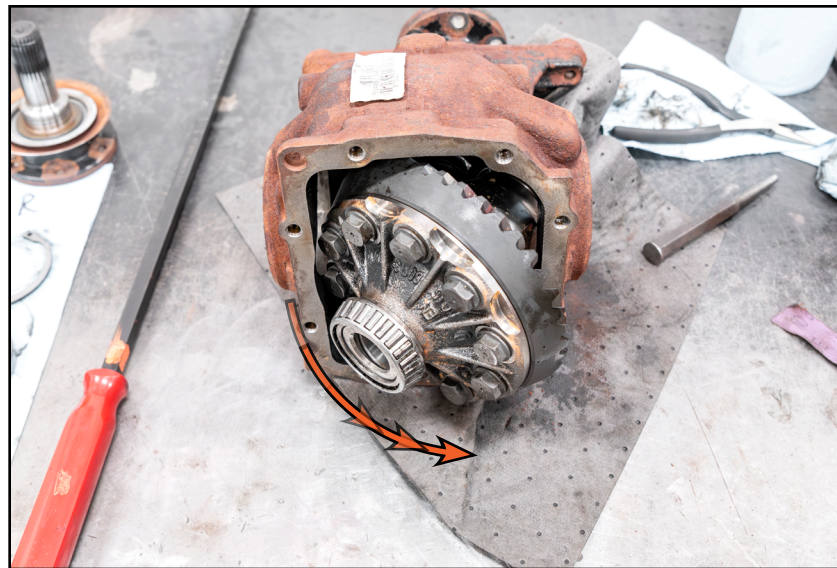

Step 10: 18mm Socket & Ratchet

Remove the 10 bolts (circled in **RED**) that secure the ring gear to the differential.



INSTALLING THE DIFFERENTIAL LOCKER

Step 11: Hammer

Thread two of the ring gear bolts back in a few turns, then, using a hammer, hit the bolt heads to drive the ring gear (highlighted in **GREEN**) off of the differential. Remove the bolts and ring gear, then clean the ring gear and set it aside.



Step 12: Hammer, Punch

Locate the dimpled end of the differential center pin (arrow) and use a hammer and punch to drive the pin out.



INSTALLING THE DIFFERENTIAL LOCKER

Step 13:

Carefully disassemble the differential and lay out the components. We will be reusing the center pin, thrust washers, and side gears. The conical spring washers and pinions will not be reused.



The thrust washers are thicker and will lay completely flat on a table, whereas the conical spring washers will not.



Step 14:

Slide the springs (highlighted in **GREEN**) into the alignment pins as shown, then clean and lubricate the alignment pins and installation pins (arrows) with fresh differential fluid.

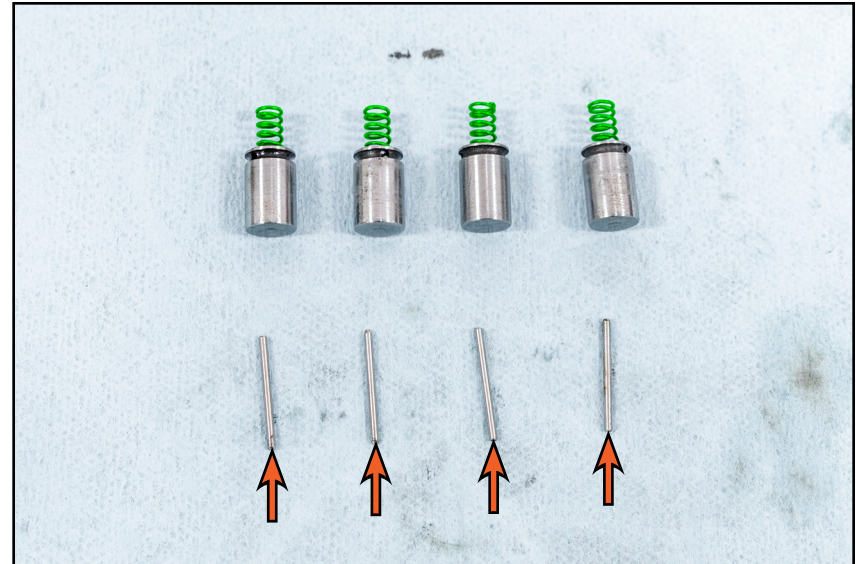

INSTALLING THE DIFFERENTIAL LOCKER

Step 15:

Slide the alignment pins (highlighted in **GREEN**) into the slots in each driver, then push each pin down and insert the installation pin (arrow) to hold it in the retracted position.

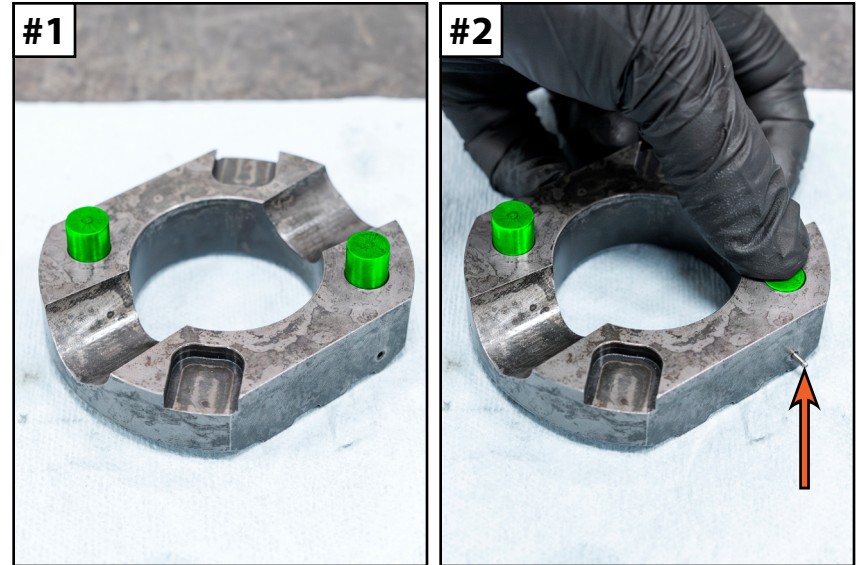

Step 16:

Reinstall the thrust washer onto one of the side gears, then install it into the differential carrier as shown.

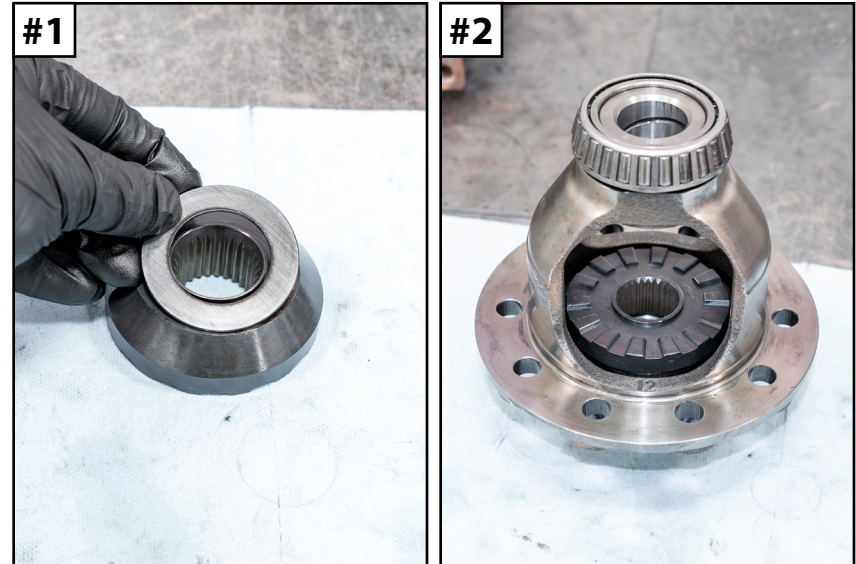

INSTALLING THE DIFFERENTIAL LOCKER

Step 17:

Install the thrust washer onto the other side gear then install it into the opposite end of the carrier, holding it in this position as shown.

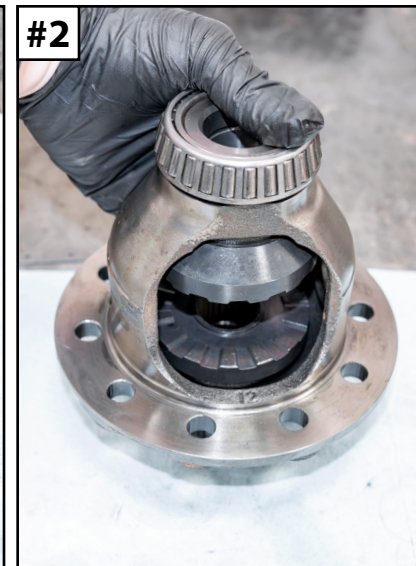
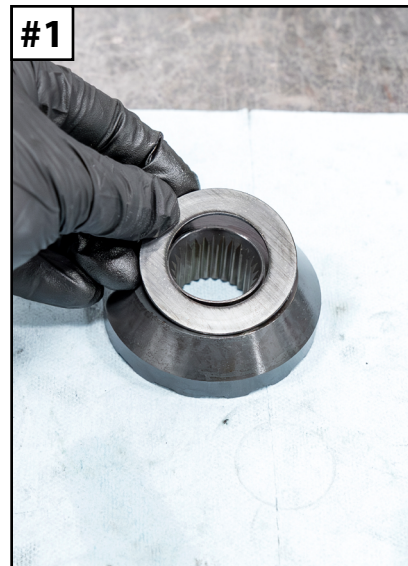

Step 18:

Slide a spacer into each driver, ensuring the flat end of the spacer faces the side of the driver with the pins installed as shown.

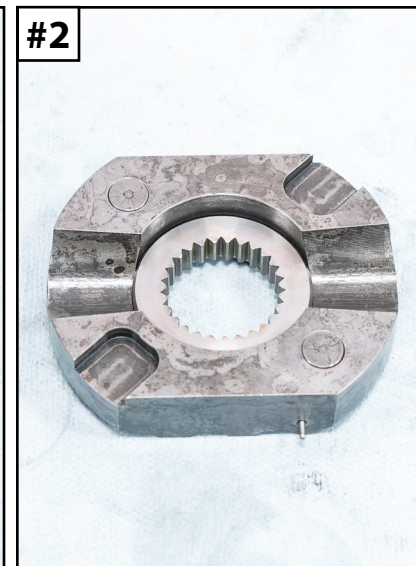
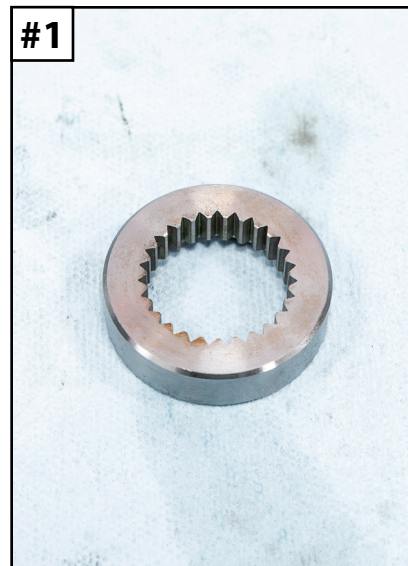

INSTALLING THE DIFFERENTIAL LOCKER

Step 19:

Slide each driver into the carrier as shown, ensuring the teeth of the driver engage the teeth on the side gears.

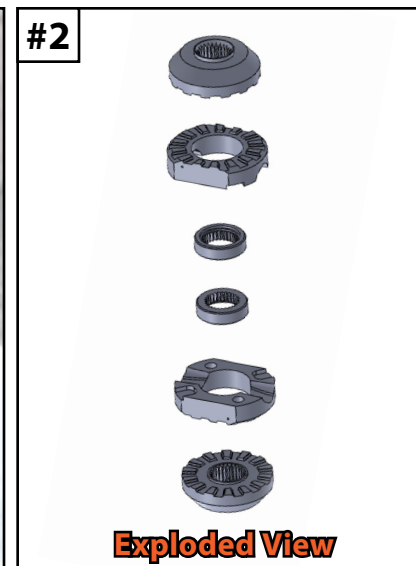
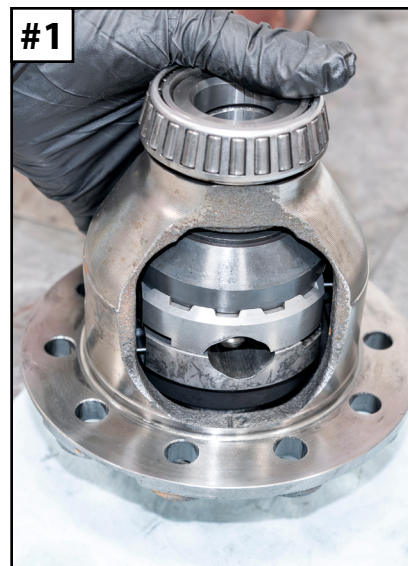

Step 20:

Rotate the differential assembly until the opening aligns with the center pin slot. Slide the center pin (highlighted in **GREEN**) into the smooth slot in the differential carrier, dimpled end first. Rotate and lift up on the driver and spacer as needed to allow the pin to pass through until it reaches the snap ring.



The upper spacer must be pushed all the way up to allow the center pin to pass through the differential assembly without contacting it.

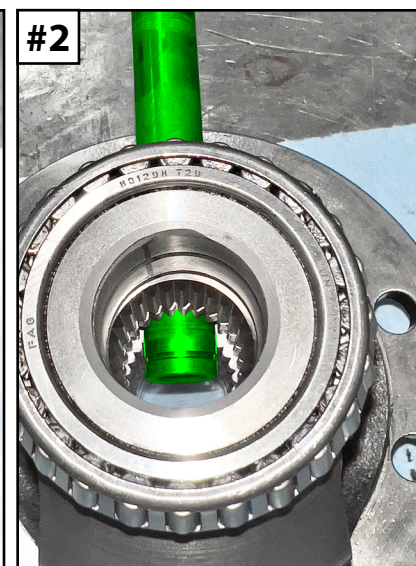
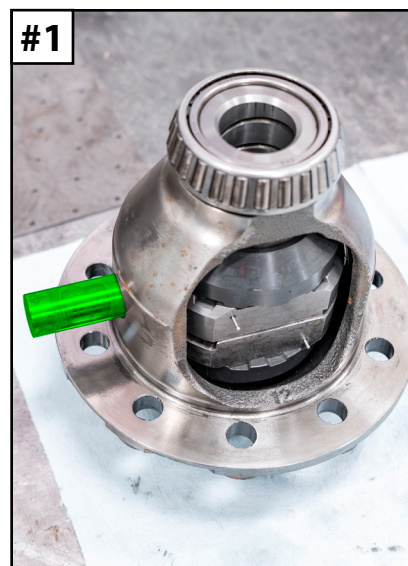

INSTALLING THE DIFFERENTIAL LOCKER

Step 21: Snap Ring Pliers, Hammer

Using a pair of snap ring pliers, expand the snap ring (highlighted in **GREEN** in inset photo) and drive the center pin past the snap ring until it engages the slot on the outside of the pin.

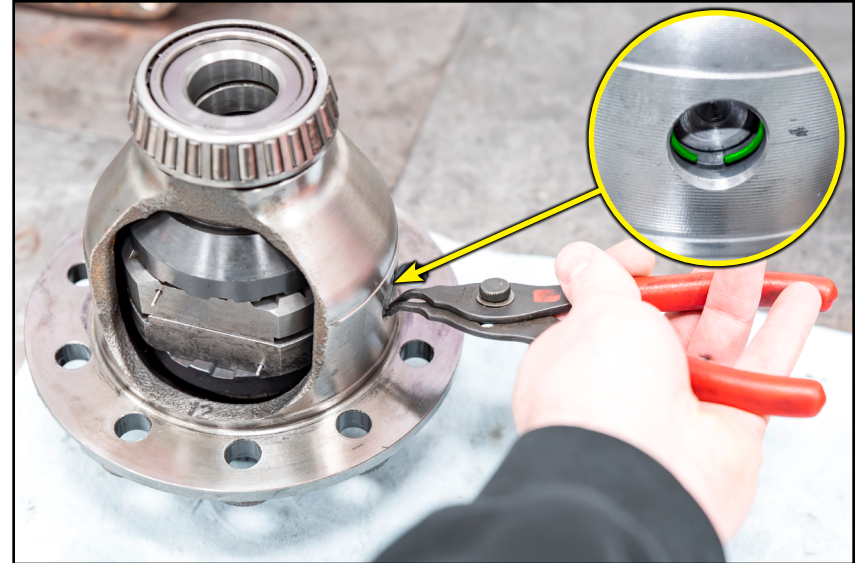

Step 22: Needle Nose Pliers

Remove the installation pins (arrows in **photo #1**) and inspect both sides of the differential to ensure the alignment pins (highlighted in **GREEN** in **photo #2**) are fully extended as shown.

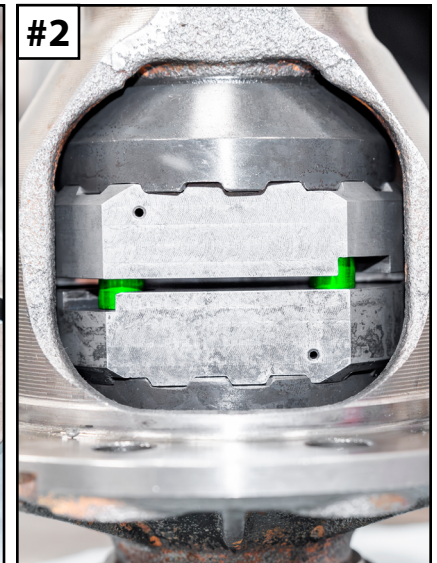
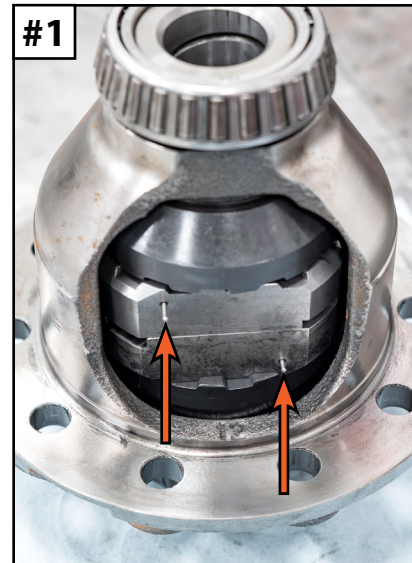

INSTALLING THE DIFFERENTIAL LOCKER

Step 23:

Thoroughly clean the ring gear bolts, then apply a small amount of blue threadlocker to the ends of the threads as shown.



Step 24: 18mm Socket & Ratchet

Lift the ring gear back into place, reinstall the bolts, and tighten the bolts in the order shown in the photo on the right, working in stages to draw the ring gear upward until it is fully seated.



INSTALLING THE DIFFERENTIAL LOCKER

Step 25:

Carefully place the differential into a bench vice, being sure not to damage the bearing.



Step 26: 18mm Socket & Torque Wrench

Torque the ring gear bolts in the order shown in [step 24](#) to 120 Nm (89 Ft-lbs).



INSTALLING THE DIFFERENTIAL LOCKER

Step 27:

Carefully pivot the differential back into the case as shown.

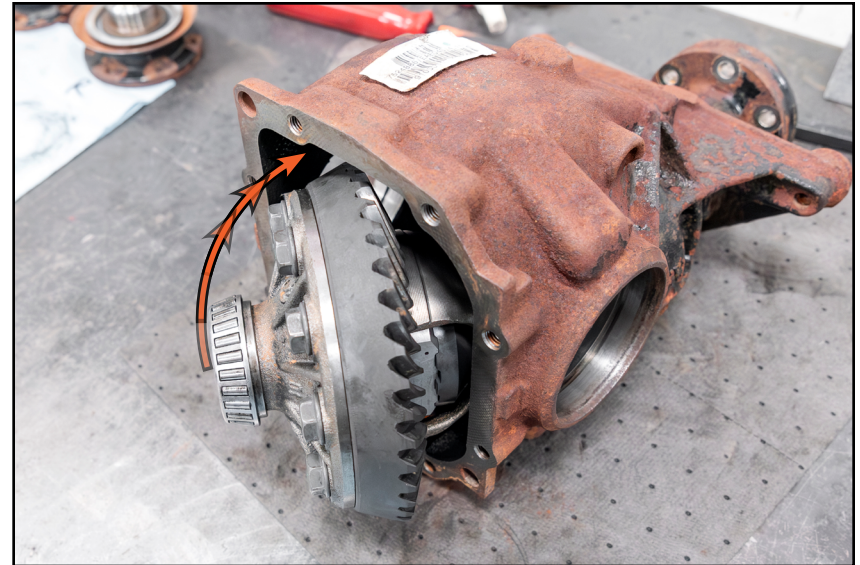

Step 28: Snap Ring Pliers

Slide the RH bearing race into place as shown, then reinstall the RH snap ring, ensuring it fully engages the groove in the differential bore.

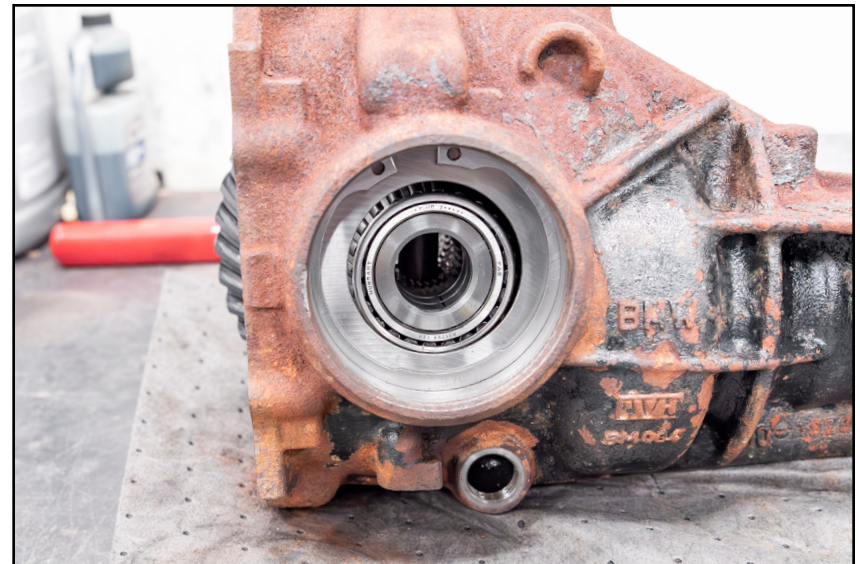

INSTALLING THE DIFFERENTIAL LOCKER

Step 29: Snap Ring Pliers

Slide the differential into the RH bearing race as far as it will go, then slide the LH bearing race and reinstall the LH snap ring.

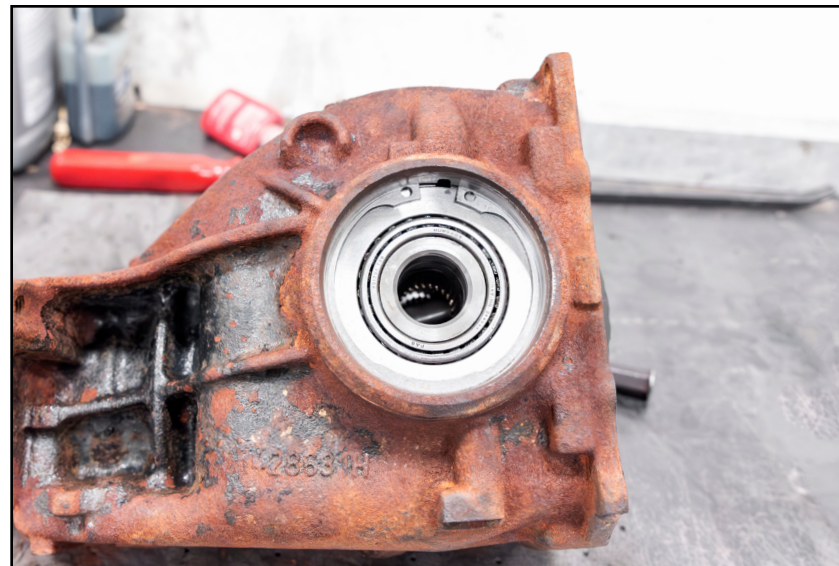

Step 30: Output Seal Installer Tool, Hammer

Using an appropriately sized output seal installer tool, drive a new output seal (highlighted in **GREEN** in **photo #2**) into each side of the differential until fully seated.

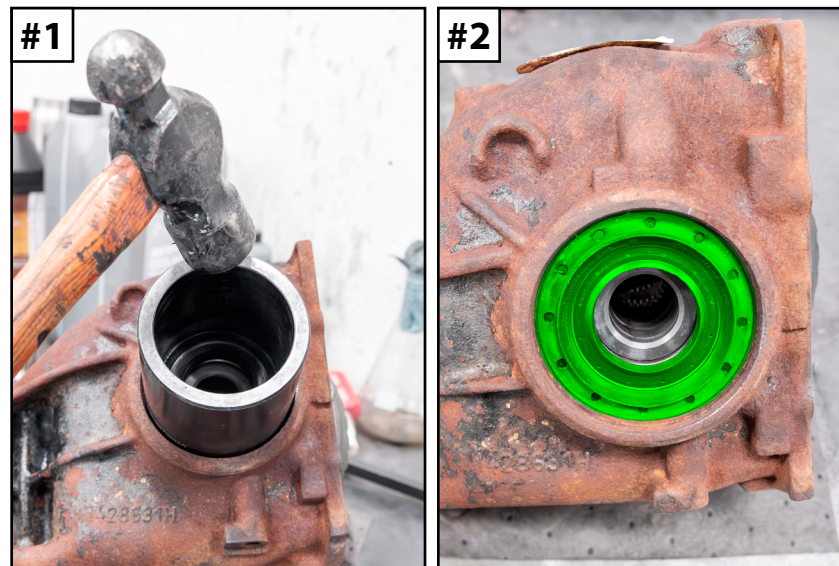

INSTALLING THE DIFFERENTIAL LOCKER

Step 31: Hammer

Slide each output shaft into the differential, rotating as needed to engage it with the splines on the side gears and spacers, then drive the shafts into place with a hammer, rotating as needed until the output shaft is fully installed and the snap ring engages on the back of the side gears.

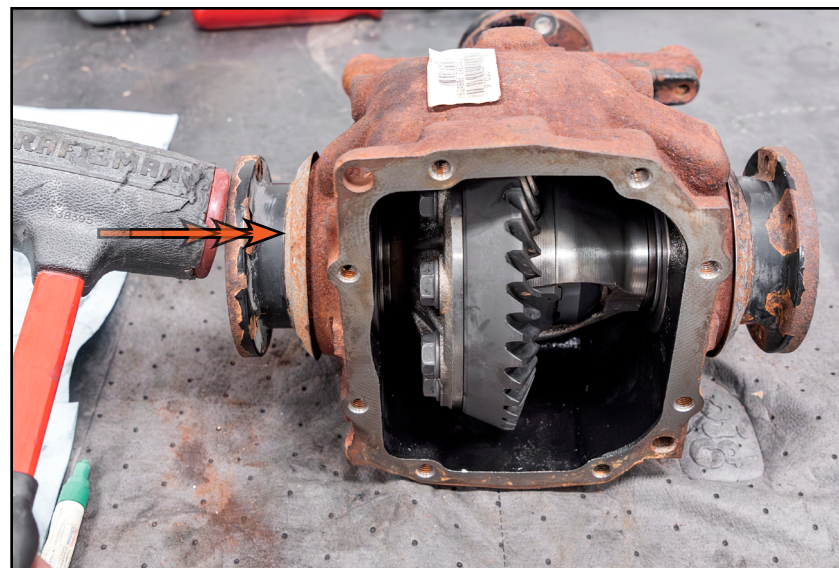

Step 32:

Thoroughly clean and prep the mating surfaces on the differential cover and case, then apply a small bead of RTV silicone gasket maker to the perimeter of the cover and around the bolts holes as shown.



INSTALLING THE DIFFERENTIAL LOCKER

Step 33: 16mm Socket & Torque Wrench

Carefully install the cover onto the case as shown, then reinstall the bolts (circled in **YELLOW**) and torque them to:

8.8 Bolts: 45 Nm (33 Ft-lbs)

10.9 Bolts: 90 Nm (66 Ft-lbs)

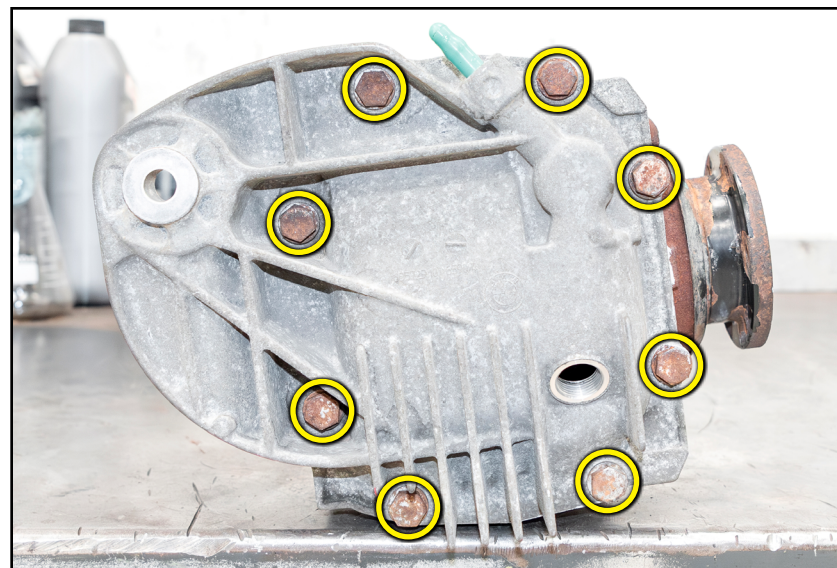

Step 34: 14mm Hex (Allen), 18mm, 21mm Socket & Torque Wrench

Reinstall the differential in reverse order of removal, torquing the bolts to:

Front bolts: 100 Nm (74 Ft-lbs)

Rear bolt: 165 Nm (122 Ft-lbs)

Reconnect the driveshaft and axles, then refill the differential with fresh fluid and torque the drain/fill plugs to 70 Nm (52 Ft-lbs).



Congratulations, your installation is complete!

Your Differential Locker installation is complete!



These instructions are provided as a courtesy by ECS Tuning

Proper service and repair procedures are vital to the safe, reliable operation of all motor vehicles as well as the personal safety of those performing the repairs. Standard safety procedures and precautions (including use of safety goggles and proper tools and equipment) should be followed at all times to eliminate the possibility of personal injury or improper service which could damage the vehicle or compromise its safety.

Although this material has been prepared with the intent to provide reliable information, no warranty (express or implied) is made as to its accuracy or completeness. Neither is any liability assumed for loss or damage resulting from reliance on this material. SPECIFICALLY, NO WARRANTY OF MERCHANTABILITY, FITNESS FOR A PARTICULAR PURPOSE OR ANY OTHER WARRANTY IS MADE OR TO BE IMPLIED WITH RESPECT TO THIS MATERIAL. In no event will ECS Tuning, Incorporated or its affiliates be liable for any damages, direct or indirect, consequential or compensatory, arising out of the use of this material.