



BMW E9x 335i Valved Exhaust System Installation Guide



*Axle-back exhaust shown



*Valved cat-back exhaust shown on N54 335i



Proper service and repair procedures are vital to the safe, reliable operation of all motor vehicles as well as the personal safety of those performing the repairs. Standard safety procedures and precautions (including use of safety goggles and proper tools and equipment) should be followed at all times to eliminate the possibility of personal injury or improper service which could damage the vehicle or compromise its safety.

TABLE OF CONTENTS

Installation and Safety Information [pg.3](#)
 Removing the Stock Exhaust System [pg.4](#)
 Remote Exhaust Valve Controller System Kit Contents [pg.6](#)
 Remote Exhaust Valve Controller System Diagram [pg.7](#)
 Installing the Remote Exhaust Valve Controller [pg.9](#)
 Installing the New Valved Exhaust System [pg.10](#)

KIT CONTENTS

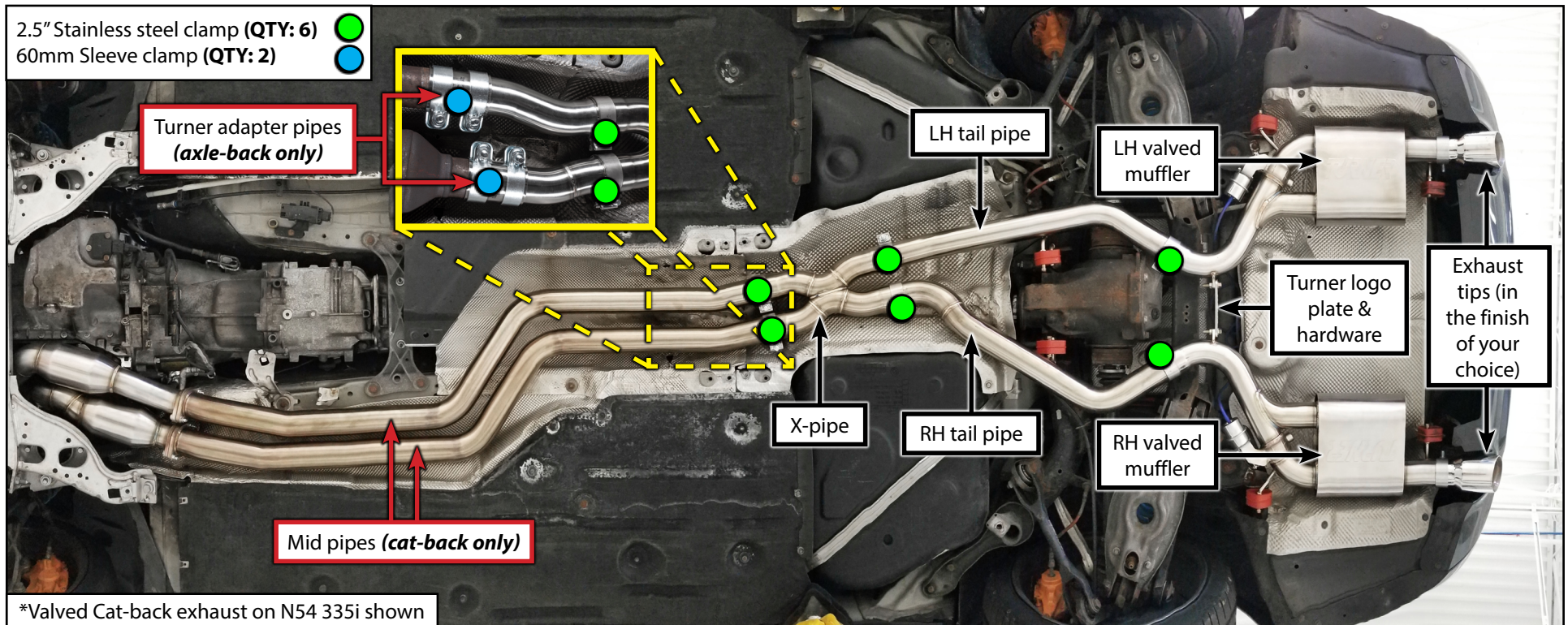

INSTALLATION NOTES

- **RH** refers to the *passenger side* of the vehicle.
- **LH** refers to the *driver side* of the vehicle.
- Always use the proper torque specifications.
- If applicable to this installation, torque specifications will be listed throughout the document and at the end as well.
- Please read all of these instructions and familiarize yourself with the complete process **BEFORE** you begin.

GENERAL PREPARATION AND SAFETY INFORMATION

Turner Motorsport cares about your health and safety, please read the following safety information. This information pertains to automotive service in general, and while it may not pertain to every job you do, please remember and share these important safety tips.

- Park your car in a safe, well lit, level area.
- Shut the engine off and remove the key from the ignition switch.
- Make sure any remote start devices are properly disabled.
- **ALWAYS** wear safety glasses.
- Make sure the parking brake is applied until the vehicle is safely lifted and supported.
- Whether lifting a vehicle using an automotive lift or a hydraulic jack, be sure and utilize the factory specified lift points.
- Lifting a vehicle in an incorrect location can cause damage to the suspension/running gear.
- **ALWAYS** support the vehicle with jack stands.
- **ALWAYS** read and follow all safety information and warnings for the equipment you are using.



NEVER get underneath a vehicle that is supported only by a jack, and **ALWAYS** make sure that the vehicle is securely supported on jack stands.

REMOVING THE STOCK EXHAUST SYSTEM

Step 1: 13mm, 16mm, 18mm Sockets, Exhaust Hanger Pliers & Exhaust Pipe Cutter

Safely lift and support the vehicle, then remove the chassis cross brace (highlighted in **RED**). Support the exhaust system from below, then release the exhaust hangers (circled in **YELLOW**) from the exhaust system, and unbolt the frontmost muffler hangers (circled in **GREEN**) from the vehicle. Safely remove and lower the exhaust system to the ground.

For cat-back systems only: Remove the nuts (arrows in inset photo) that secure the exhaust system to the catalytic converters, then remove the bolts (circled in **RED**) that secure the exhaust bracket to the transmission crossmember. Skip ahead to page 6.



For axle-back systems only: The exhaust system must be cut (**RED** dotted lines) downstream of the secondary catalytic converters. Proceed to the next page for instructions on cutting the exhaust system.

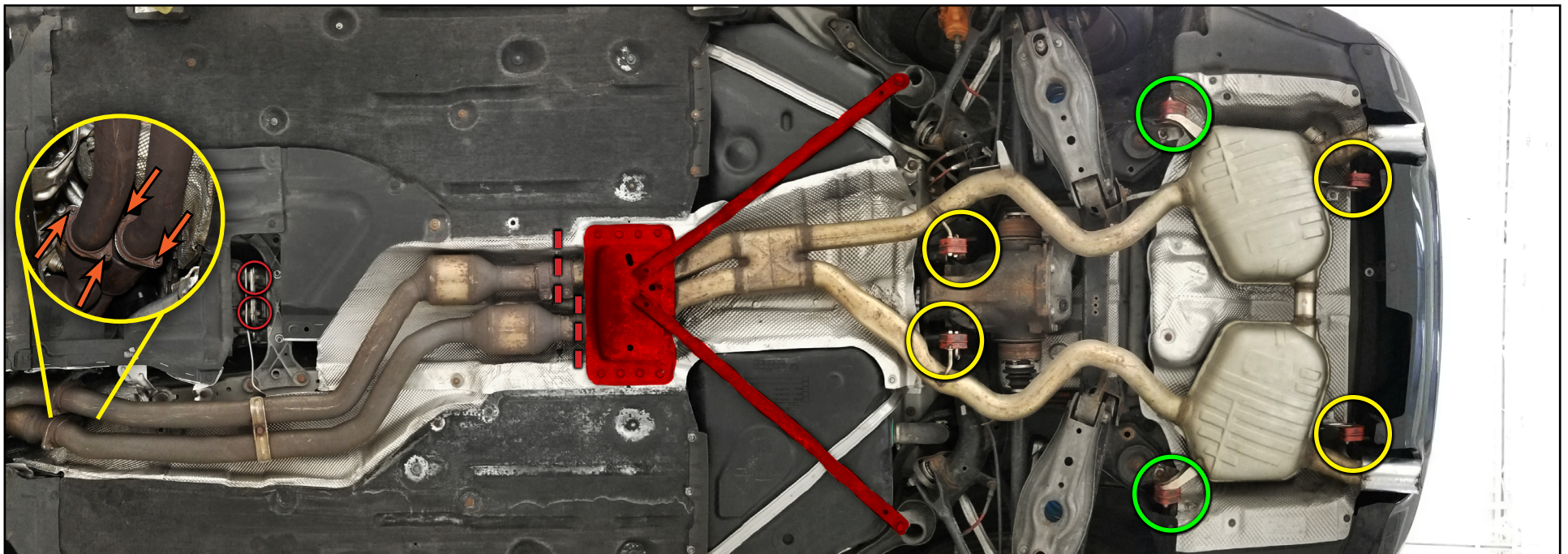

REMOVING THE STOCK EXHAUST SYSTEM

Step 2: Marker - OR - Masking Tape

Axle-back exhaust systems only: Measure 5" (127mm) downstream from the weld on the LH secondary catalytic converter, then measure 2" (51mm) downstream from the weld on the RH secondary catalytic converter, and mark the pipes to be cut.

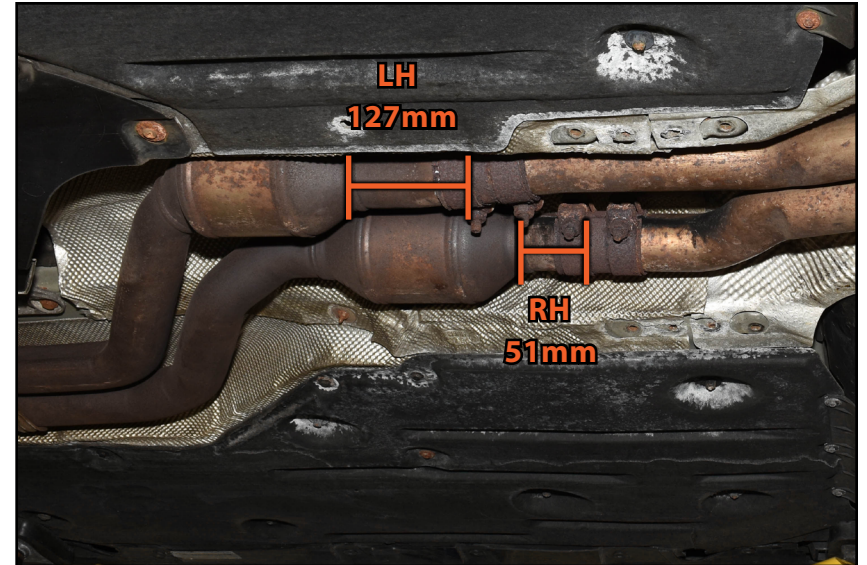

Step 3: Exhaust Pipe Cutter, Metal File - OR - Die Grinder

Axle-back exhaust systems only: Cut along the line (RED dotted lines), being sure to cut as straight as possible until you cut all the way through the pipe. Use a metal file or die grinder to remove any burrs from the exhaust pipes that we cut, this will ensure a proper fit and seal.



It is **absolutely imperative** that you take your time here and double or triple check your marks before you cut anything.



REMOTE EXHAUST VALVE CONTROLLER KIT CONTENTS

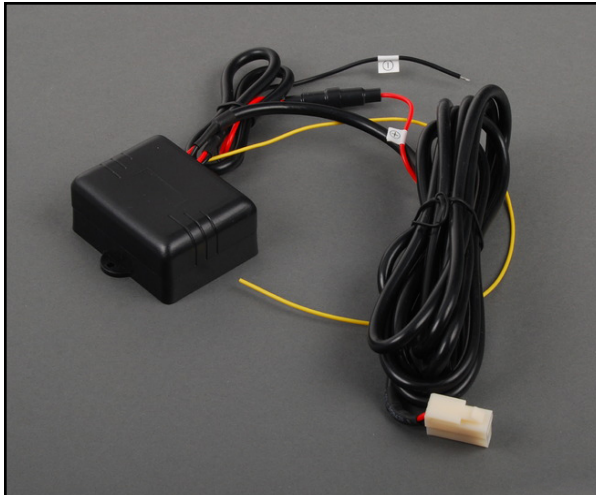

Control Module with Wiring Harness (QTY 1)



Vacuum Hose (1x long, 1x short)



Remote Controllers (QTY 2)

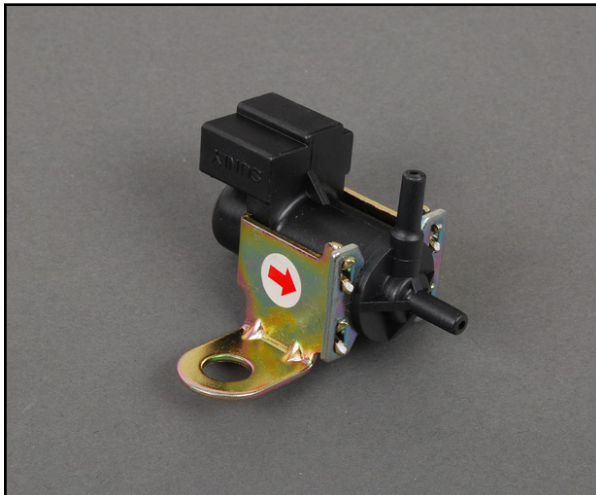

Solenoid Vacuum Valve (QTY 1)



Check Valve (QTY 1)



Vacuum Hose T-Fitting (QTY 2)

REMOTE EXHAUST VALVE CONTROLLER SYSTEM DIAGRAM

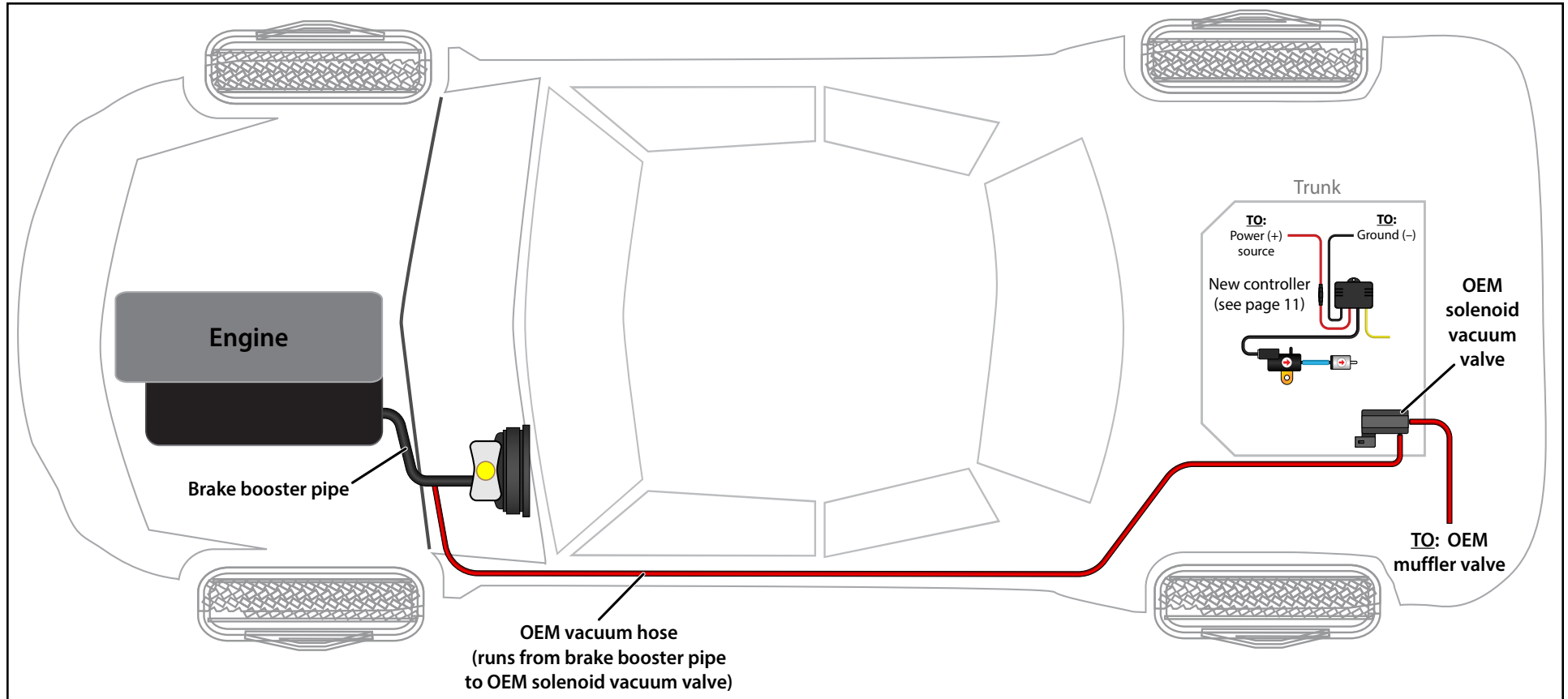

There is an OEM vacuum hose (highlighted in **RED** above) which connects the brake booster pipe to the OEM solenoid vacuum valve (located inside the trunk behind the LH tail light). Our goal is to use that hose to supply vacuum to our **NEW** solenoid vacuum valve. We include extra hose in the kit just in case you need it.

We recommend using an [Add-A-Circuit Fuse Holder](#) to power the control module by tapping into an **IGNITION LIVE** fuse. This means that the control module will not be powered unless the key is turned **ON**. For more information on this please see the PDF which is located under the "Installation" tab on [ES#1906431](#) or [ES#3209653](#). Connect the ground wire to a nearby chassis ground.

Proceed to the next page for a detailed diagram of the entire valve controller system.

REMOTE EXHAUST VALVE CONTROLLER SYSTEM DIAGRAM

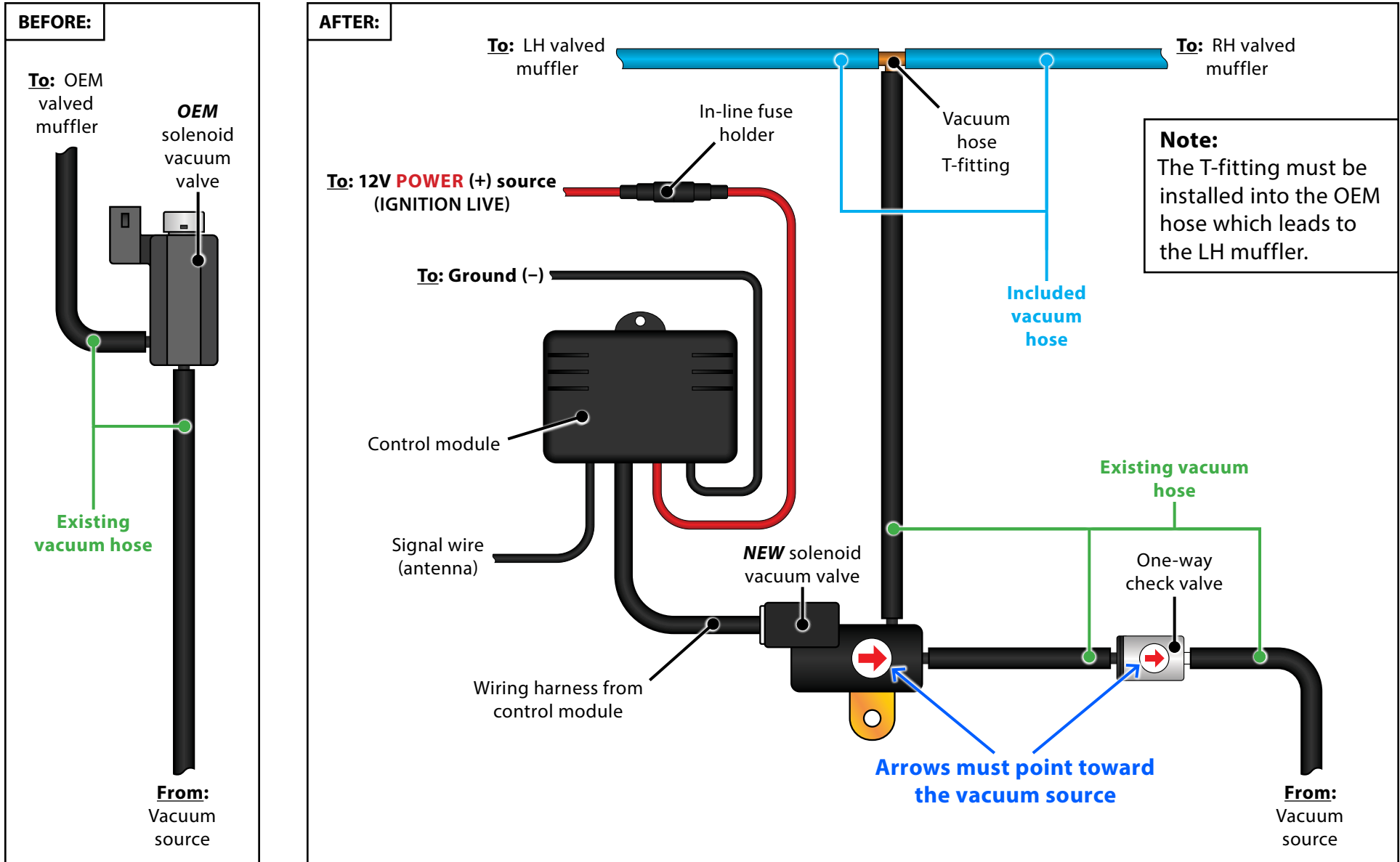

INSTALLING THE REMOTE EXHAUST VALVE CONTROLLER

Step 1:

Remove the vacuum hoses from the OEM solenoid vacuum valve (located inside the trunk behind the LH tail light) and connect them to the new solenoid vacuum valve. Be sure to install the new one-way check valve into the supply hose. Reference the diagrams on [Page 8](#).

Mount the new solenoid and control module. Connect the power wire to a nearby ignition-live power source. Connect the ground wire to a nearby chassis ground.

Working beneath the vehicle, find the hose that leads to the OEM muffler valve and install the T-fitting. Connect the provided vacuum hose from the T-fitting to where the new mufflers will be when installed.

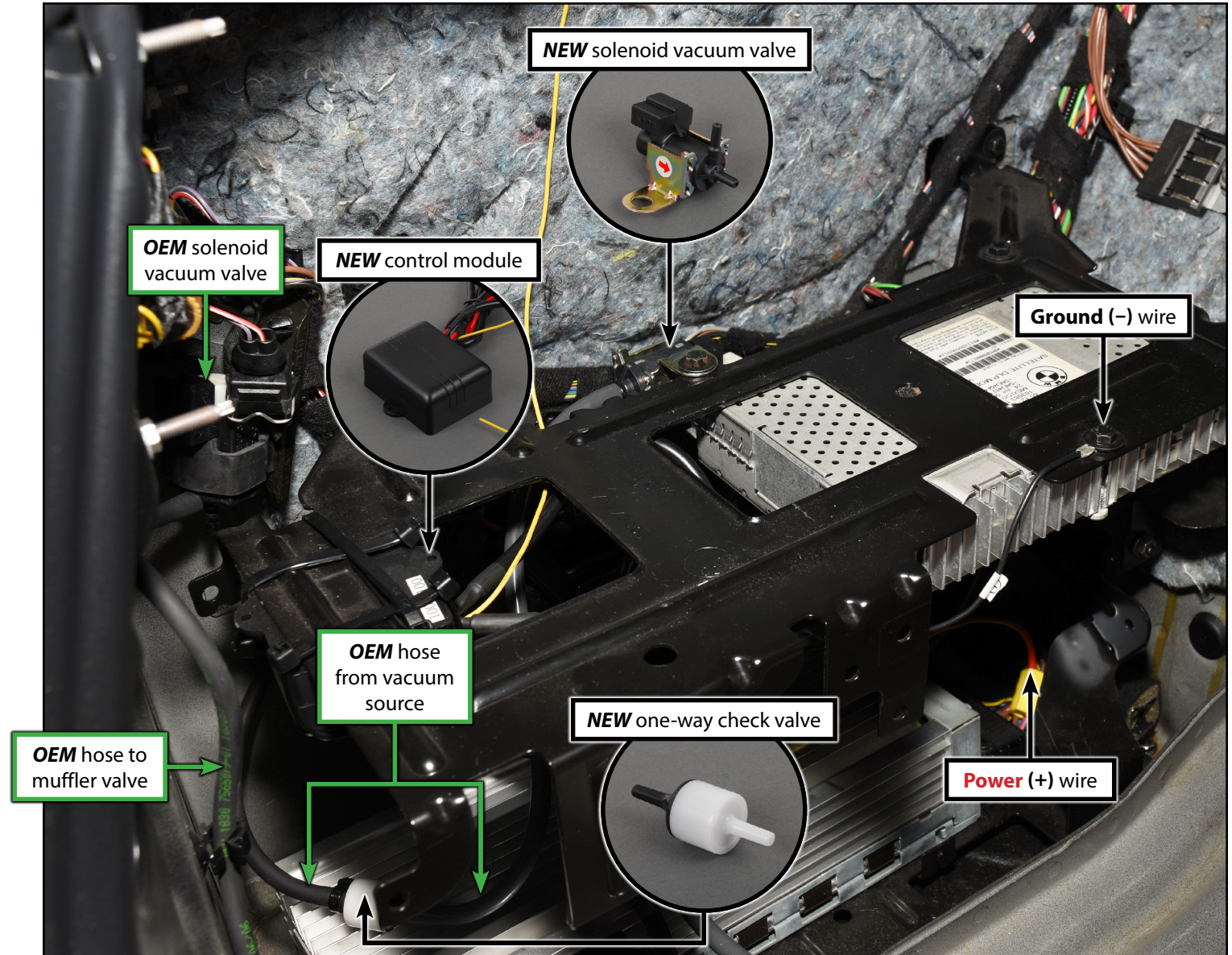

INSTALLING THE NEW VALVED EXHAUST SYSTEM

Step 1:

Before we begin it's a good idea to unpack your new exhaust system and carefully lay it out on the floor. Inspect all of the slip joints for any signs of damage during shipping.

Please note that during this installation, you will be installing the exhaust from front to back **WITHOUT** tightening any of the clamps. Once the system is installed, we will then show you how to position the system properly and you will tighten the clamps **AFTER** that is complete. Proceed to the next page once all of the slip joints slide together easily.

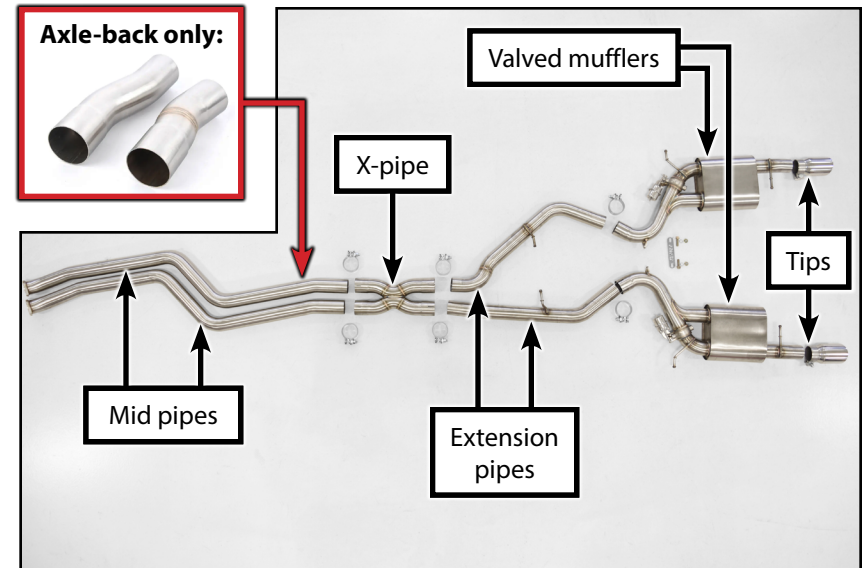

Step 2: Pipe Expander - OR - Ball Pein Hammer

Test fit the pipes together at every slip joint to make sure they slide together easily. If they do not slide together easily, use a pipe expander tool or gently tap on the ends of the pipes with a ball pein hammer to straighten them, then recheck fitment.

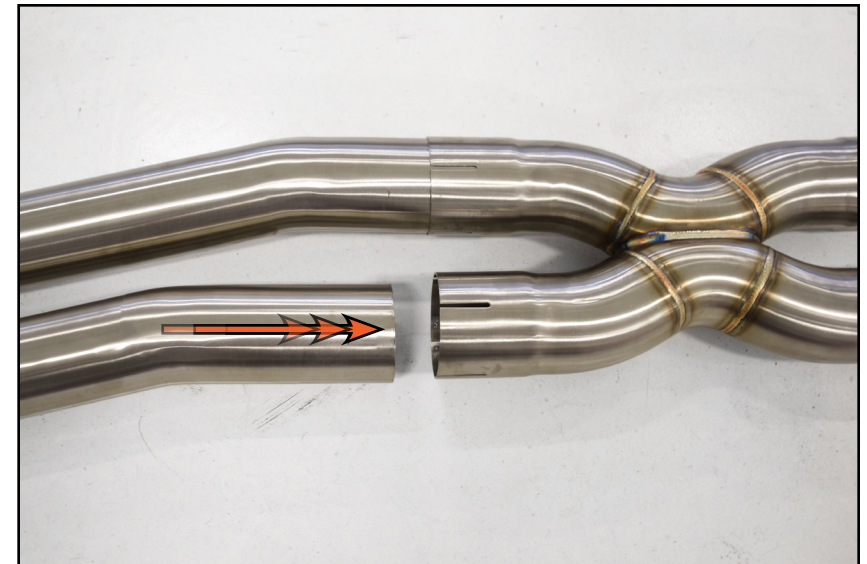

INSTALLING THE NEW VALVED EXHAUST SYSTEM

Step 3: Exhaust Hanger Remover Pliers

Transfer the exhaust hangers (arrows) from the stock exhaust system to the new valved mufflers as shown.



Axleback exhaust systems: Skip ahead to page 12.



Step 4:

Cat-back exhaust systems only: Clean the ends of the catalytic converter flanges with a suitable degreaser or brake cleaner. Replace the gaskets (arrows) with the new ones provided in the kit.

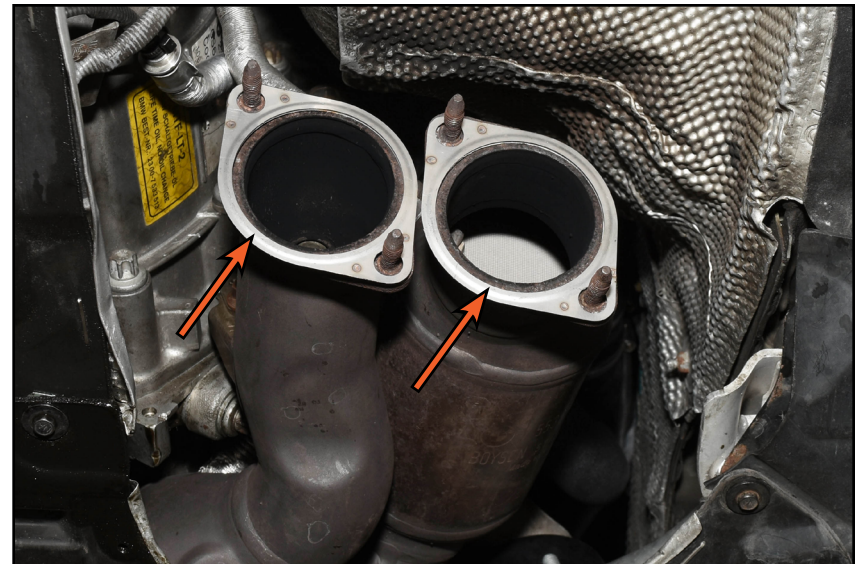

INSTALLING THE NEW VALVED EXHAUST SYSTEM

Step 5: 13mm, 15mm, 16mm, 18mm Sockets & Ratchet

Loosely install the exhaust system from front to back, then reconnect the hangers (circled in **YELLOW**), and resecure the frontmost muffler hangers (circled in **GREEN**).

Install the logo plate (arrow).

Tighten all of the exhaust clamps until snug, but leave them loose enough to allow you to adjust the system for proper fitment. The key to proper adjustment is patience, take your time and **DO NOT** fully tighten any of the clamps until **AFTER** you've performed all of the steps up through Page 14.

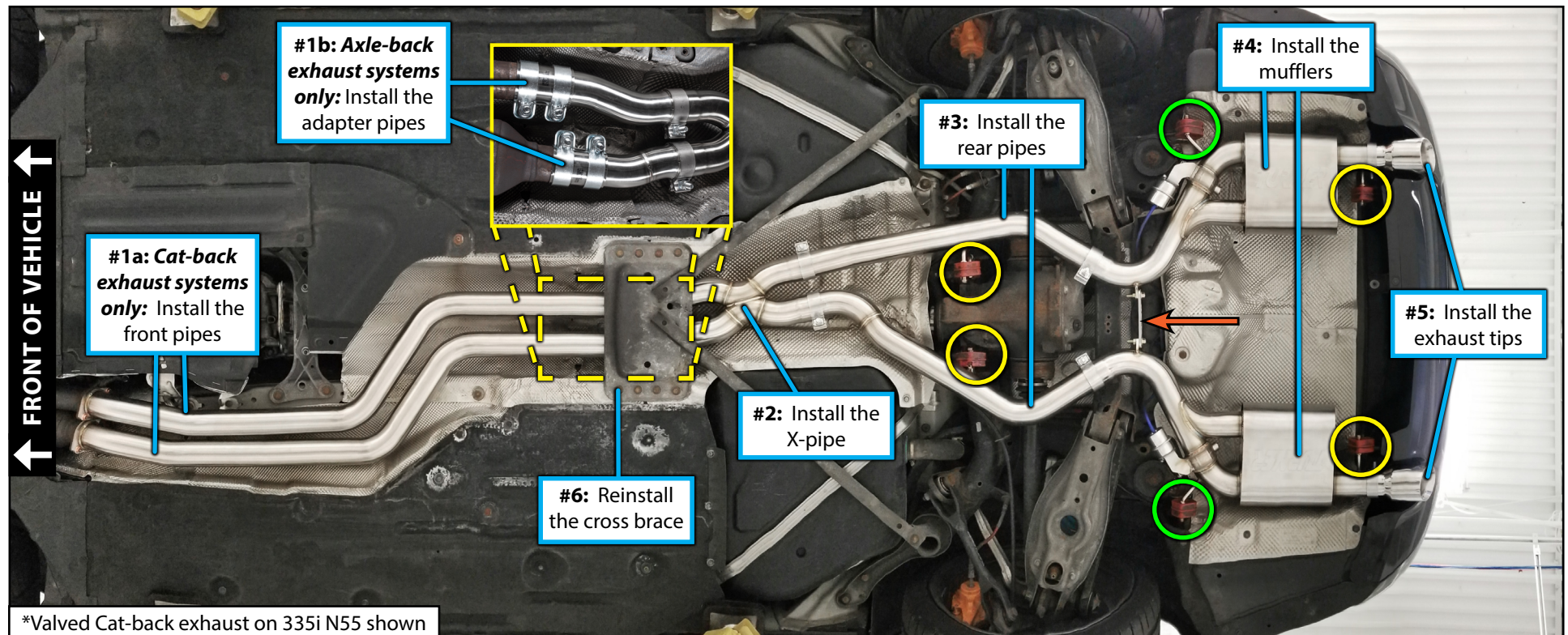

INSTALLING THE NEW VALVED EXHAUST SYSTEM

Step 6:

Check the hangers on the muffler and rear pipes to ensure that they are sitting level side-to-side (**Photos #1 & #2 below**).

Finally, we want to ensure that the exhaust hangers are rotated at least slightly toward the front of the vehicle (**Photo #3 below**). The exhaust hangers should be inclined toward the front of the vehicle so that lower hole is approximately 10-15mm forward of the upper hole, this will allow the hangers to pivot backwards as the system heats up and expands.



Due to differences in manufacturing, as well as variations from one car to another, you might not be able to get all of your hangers to pitch forward. This is acceptable as long as they are at least close to vertical.



CAUTION: You can tighten the exhaust clamps until they are “snug”, but **DO NOT USE AN IMPACT WRENCH** and do not fully tighten them yet!

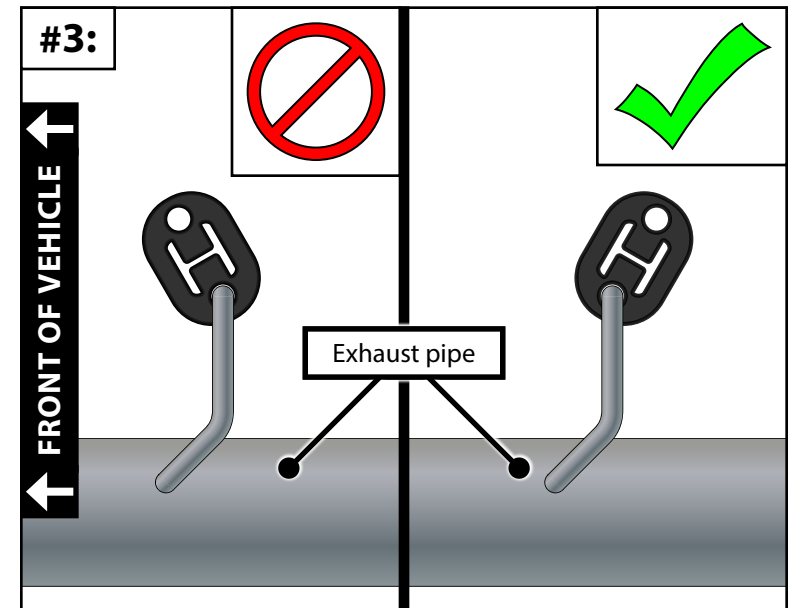
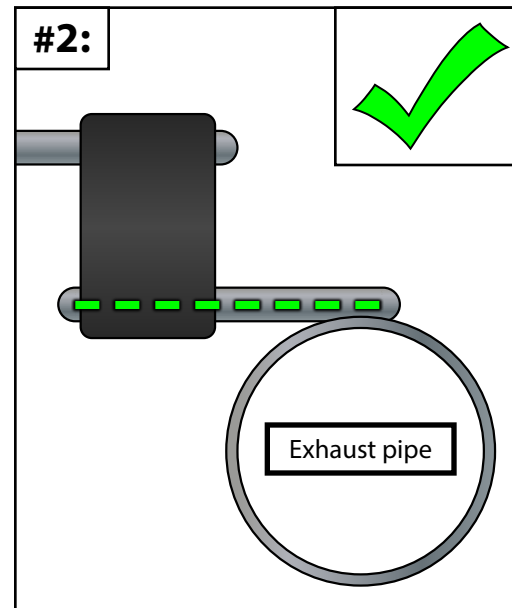
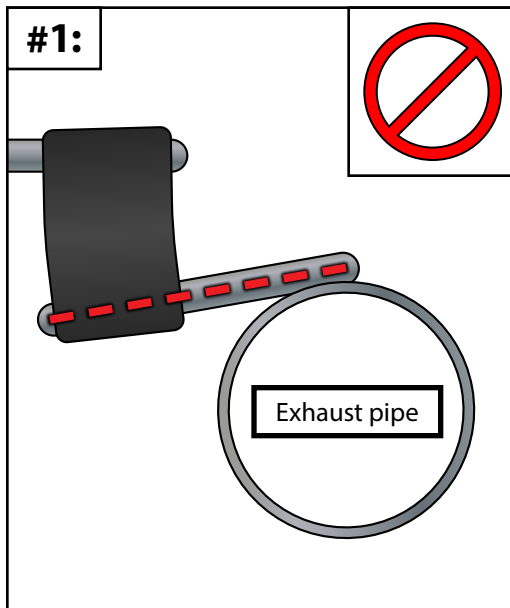

INSTALLING THE NEW VALVED EXHAUST SYSTEM

Step 7: 15mm Socket & Ratchet

Ensure the mufflers and logo plate are sitting level from side to side (**Photo #1**). Push upward on the exhaust system as you fully tighten each clamp from the front of the system to the back. Allow the exhaust to settle, then check again for clearance around all pipes. Center and level each of the exhaust tips (**Photo #2**) inside the bumper cut outs, then torque the exhaust tip clamps to 19 Nm (14 Ft-lbs). Connect the vacuum hoses (arrows in **Photo #3**) to the valve on each muffler.

Wipe any oil, grease, or fingerprints from the exhaust system.

Recheck all fasteners after the vehicle has been driven 500 miles.

Ensure proper valve functionality.

Congratulations, your installation is complete!

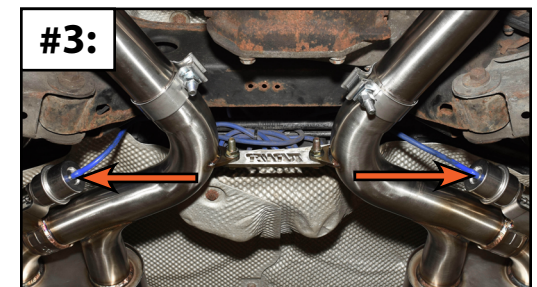
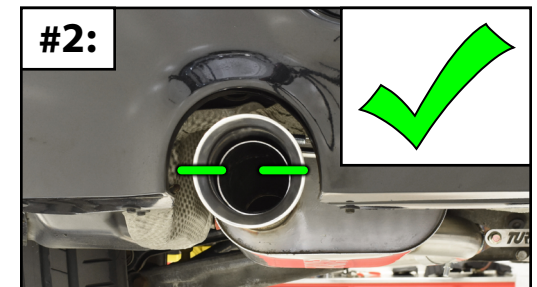

Your Valved Exhaust System installation is complete!



These instructions are provided as a courtesy by Turner Motorsport

Proper service and repair procedures are vital to the safe, reliable operation of all motor vehicles as well as the personal safety of those performing the repairs. Standard safety procedures and precautions (including use of safety goggles and proper tools and equipment) should be followed at all times to eliminate the possibility of personal injury or improper service which could damage the vehicle or compromise its safety.

Although this material has been prepared with the intent to provide reliable information, no warranty (express or implied) is made as to its accuracy or completeness. Neither is any liability assumed for loss or damage resulting from reliance on this material. SPECIFICALLY, NO WARRANTY OF MERCHANTABILITY, FITNESS FOR A PARTICULAR PURPOSE OR ANY OTHER WARRANTY IS MADE OR TO BE IMPLIED WITH RESPECT TO THIS MATERIAL. In no event will Turner Motorsport, Incorporated or its affiliates be liable for any damages, direct or indirect, consequential or compensatory, arising out of the use of this material.